



MSA SERIES

Heavy Duty Gas Griddles



SELL SHEET

Model MSA48



SPECIFIER STATEMENT

Low profile heavy duty gas griddle, Vulcan Model No. _____. Stainless steel front, sides and front top ledge. Fully welded stainless and aluminized steel body frame. 11" low profile cooking height on 4" legs. 1" thick polished steel griddle plate with 12 gage, 4" stainless steel back and tapered side splashes. Grease chute is fully welded to stop grease migration. One 27,000 BTU/hr. "U" shaped aluminized steel burner and mechanical snap action thermostat for each 12" of griddle width. Chrome thermostat knob guards. Temperature adjusts from 200° to 550°F. One pilot safety for every two burners. 3½" wide stainless steel grease trough. ¾" rear gas connection and gas pressure regulator.

Exterior Dimensions:

_____ "w x 33" d x 15½" h on 4" legs.

CSA design certified. NSF listed.

SPECIFY TYPE OF GAS WHEN ORDERING
SPECIFY ALTITUDE WHEN ABOVE 2,000 FT.

Project _____
AIA # _____ SIS # _____
Item # _____ Quantity _____ C.S.I. Section 114000

MODELS

- MSA24:** 24" w x 24" d griddle plate
- MSA36:** 36" w x 24" d griddle plate
- MSA48:** 48" w x 24" d griddle plate
- MSA60:** 60" w x 24" d griddle plate
- MSA72:** 72" w x 24" d griddle plate

STANDARD FEATURES

- Stainless steel front, sides and front top ledge with "Cool Bullnose" design
- Fully welded stainless and aluminized steel chassis frame
- 11" low profile cooking height on 4" adjustable legs
- 1" thick polished steel griddle plate with 12 gage, 4" stainless steel back and tapered side splashes
- Spatula wide 3½" grease gutter and chute is fully welded for easier cleaning and to stop grease migration
- One 27,000 BTU/hr. "U" shaped aluminized steel burner for every 12" of griddle width
- One embedded snap action thermostat per burner with temperature adjust from 200°F to 550°F on Steel or Chrome plate; temperature adjusts from 200°F to 450°F on Rapid Recovery™ plate
- Large 6 quart stainless steel grease drawer (2 drawers on 60" and 72" models)
- Heavy duty chromed thermostat knob guards
- One pilot safety valve for every two burners; safety will completely shut off gas to pilot and burners if pilot extinguishes
- Manual ignition
- Bottom heat shields
- ¾" rear gas connection and gas pressure regulator
- One year limited parts and labor warranty

OPTIONS

- Full or partially grooved griddle plate (steel or chrome plate only)
- Rapid Recovery™ griddle plate (200-450°F controls, 48" maximum length)
- Hexavalent chrome plated cooking surface
- 30" deep plate (steel plate only)
- Stainless steel stand with marine edges and casters
- Cutting board, condiment rail, plate rail and banking strip accessories

MSA SERIES – Heavy Duty Gas Griddles

Approved by _____ Date _____ Approved by _____ Date _____

INSTALLATION INSTRUCTIONS INSTALLATION MANUAL

1. A gas pressure regulator supplied with the unit must be installed;
Natural Gas 4.0" (102 mm) W.C.
Propane Gas 10.0" (254 mm) W.C.
2. All models require a 6" (152 mm) clearance at both sides and rear adjacent to combustible and 0" from non-combustible constructions. All models require a 4" (102mm) bottom clearance and must be installed with minimum 4" legs.
3. These units are manufactured for installation in accordance with ANSI/NFPA-70, National Electrical code.

An adequate ventilation system is required for Commercial Cooking Equipment (NFPA No. 96). Information may be obtained by writing to the National Fire Protection Association, Batterymarch Park, Quincy, MA 02169.

4. These units are manufactured for installation in accordance with National Fuel Gas Code, ANSI-Z223.1/NFPA #54 (latest edition). Copies may be obtained from The American Gas Association, Accredited Standards Committee Z223 @ 400 N. Capital St. NW, Washington, DC 20001, or the Secretary Standards Council, NFPA, 1 Batterymarch Park, Quincy, MA 02169-7471.

NOTE: In The Commonwealth of Massachusetts

All gas appliances vented through ventilation hood or exhaust system equipped with a damper or with a power means of exhaust shall comply with 248 CMR.

5. This appliance is manufactured for commercial installation only and is not intended for home use.

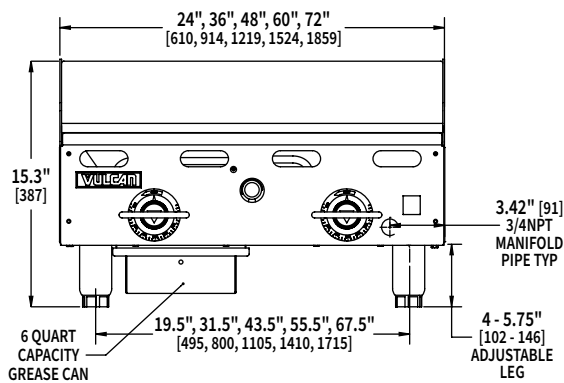

Front View

NOTES:

1. ADJUSTABLE LEGS ARE 2" IN DIAMETER. LEGS ARE RECESSED 1/4" FROM EACH SIDE.

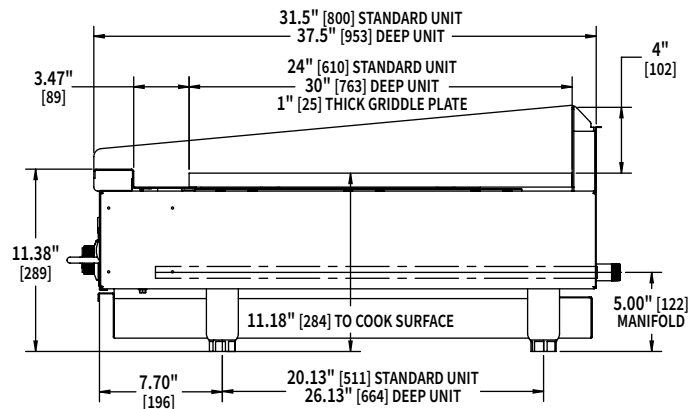

Front Grease Trough - Side View

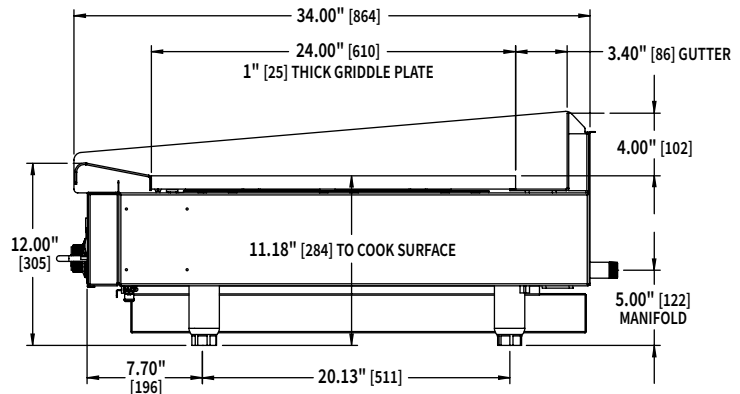

Rear Grease Trough - Side View

▶ CAD and/or Revit Files Available

Model	Width	Depth	Overall Height*	Working Height*	Number of Burners	Total BTU/Hr.	Number of Drawers	Approximate Shipping Weight
MSA24	24"	31½"	15¼"	11⅞"	2	54,000	1	285 lbs./129 kg.
MSA36	36"	31½"	15¼"	11⅞"	3	81,000	1	400 lbs./181 kg.
MSA48	48"	31½"	15¼"	11⅞"	4	108,000	1	480 lbs./218 kg.
MSA60	60"	31½"	15¼"	11⅞"	5	135,000	2	650 lbs./295 kg.
MSA72	72"	31½"	15¼"	11⅞"	6	162,000	2	790 lbs./358 kg.

*These are nominal dimensions and can vary by +1.75" with adjustable legs.

As continued product improvement is a policy of Vulcan, specifications are subject to change without notice.