

REFRIGERATION

BEER DISPENSERS WITH TRIPLE DOOR AND 2 SPOUTS

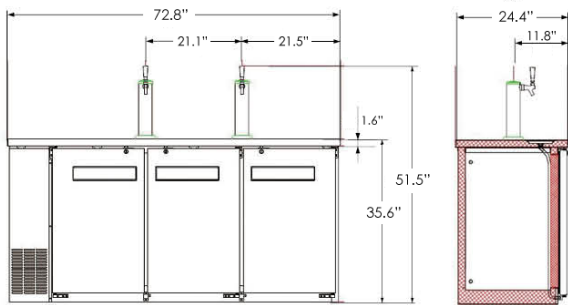

Features:

- Durable stainless steel top, interior walls, floor and ceiling
- Exterior construction is attractive corrosion resistant vinyl on steel in black finish
- Refrigeration system keeps the drinks at safe temperatures between 33°F and 41°F (0.5°C to 5°C)
- Shelves: Adjustable heavy-duty PVC coated shelves
- Self-Closing doors with locks
- LED interior lighting
- Removable installation board makes it easy to access condenser coil for cleaning and service
- Refrigerant: HYDRO-CARBON R290

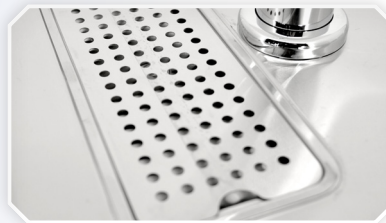

Stainless steel top tray cover



Optional order (Item 44224):
Double tap tower



Shelf

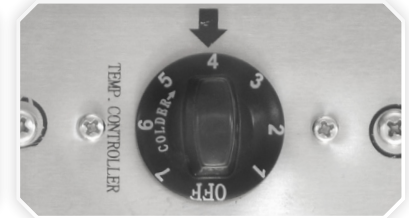

Mechanical temperature controller

TECHNICAL SPECIFICATION

ITEM NUMBER	50065	COMPRESSOR HP	1/4+
MODEL	BB-CN-0020-DH	ELECTRICAL	115V / 60Hz / 1Ph
POWER	196 kW	AMPS	4
PRODUCT CAPACITY	Three 1/2 barrels	OVERALL DIMENSIONS (DWH)	24.4" x 72.8" x 51.5" / 1848 x 620 x 905 mm
NUMBER OF DOORS	3	INTERIOR DIMENSIONS	60 1/8" x 18 1/2" x 30 1/2" / 1528 x 470 x 775 mm
TEMPERATURE RANGE	0.5 - 5 °C / 33 - 41 °F	PACKAGING DIMENSIONS	75 2/8" x 27 4/8" x 42 3/8" / 1910 x 700 x 1075 mm
CAPACITY	19.6 cu. ft.	WEIGHT	141 kg. / 310 lbs.
NUMBER OF SHELVES	6	PACKAGING WEIGHT	175 kg. / 385 lbs.

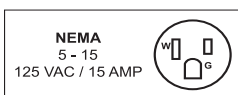

OMCAN INC.

Telephone: 1-800-465-0234

Fax: (905) 607-0234

Email: sales@omcan.com

Website: www.omcan.com



Follow us to keep up to date with the latest news and offers



2017.E.O.E